

Industry-Series



Non-contact flow measurement for wastewater, sewage systems and industrial waters



Distributed by:

Lab Unlimited
CARL STUART GROUP

Tallaght Business Park
Whitestown, Dublin 24,
Ireland
D24 RFK3

Tel: (01) 4523432
Fax: (01) 4523967
E-mail: info@labunlimited.com
Web: www.labunlimited.com

Quatro House, Frimley Road,
Camberley,
United Kingdom
GU16 7ER

Tel: 08452 30 40 30
Fax: 08452 30 50 30
E-mail: info@labunlimited.co.uk
Web: www.labunlimited.co.uk

somer
MESSTECHNIK



Non-contact monitoring Innovative radar measurement technology as key

The flow meters of the SQ-series capture continuously and contact-free the flow rate of sewer systems, ducts, semi-filled pipes and other technical channels in the fields of wastewater and industrial effluents.

The discharge calculation of the sensor, which is very easy to install and to set up, is based on a hydraulic model. Non-contact level and flow velocity measurement is achieved using up-to-date radar technology, whereby the level is measured by means of ultrasonic or alternatively by radar technology.

The series consists of the different types SQ-U and SQ-8R according to the level to be measured.



Pic: SQ-Sensor

Maintenance-free and fail-safe Advantages of the non-contact measurement

Since there is no direct contact to the wastewater, the measurement device remains free from soiling or deposits, as this frequently happens with submerged type sensors.

The customer gains from **maintenance-free operation** and **increased reliability**. Moreover, the sealed, UV and acid resistant housing of the SQ (rated protection class IP 68) withstands surcharge events and protects the valuable measurement equipment against aggressive atmospheres.



Pic: SQ-Sensor installed



METAS
Federal Office
of Metrology

Certificated accuracy

The accuracy of the flow velocity sensor has been certificated by METAS, the well-known Swiss Federal Institute of Metrology.



Measuring principle

Flow velocity

The measurement of the surface flow velocity is based on the Doppler frequency shift method: A radar signal is transmitted to the water surface at a constant frequency of 24 GHz. The sensor measures the partially reflected signal whose frequency is shifted due to the water movement. The surface velocity is determined through a spectral analysis. Finally, the mean velocity results by applying an integrated hydraulic model and is used for the calculation of the discharge (flow rate).

Flow rate

The flow rate **Q** is determined by the continuity equation.

$$Q = v_m \cdot A(h)$$

Based on the cross-section profile at the measuring site the wetted cross-sectional area **A(h)** is determined depending on the water level. According to the hydraulic calculation the mean velocity **v_m** results from the local surface velocity **v_l** measured by the SQ sensor.

Hence, the flow can be determined and outputted directly from the flow velocity and the water level. The sensor set-up and site calibration is done by the specifically developed and intelligent sensor software **Q-Commander**.

Level

The water level is calculated using a travel time measurement. The device sends short pulses perpendicularly to the water surface. The distance to the water surface and yet the corresponding actual water level can be calculated by measuring the time interval from the emission to the reception of the reflected impulses. Optionally and according to individual requirements the level can be measured by an ultrasonic or a radar sensor. If there is considerable foam on the surface the radar delivers more reliable results.

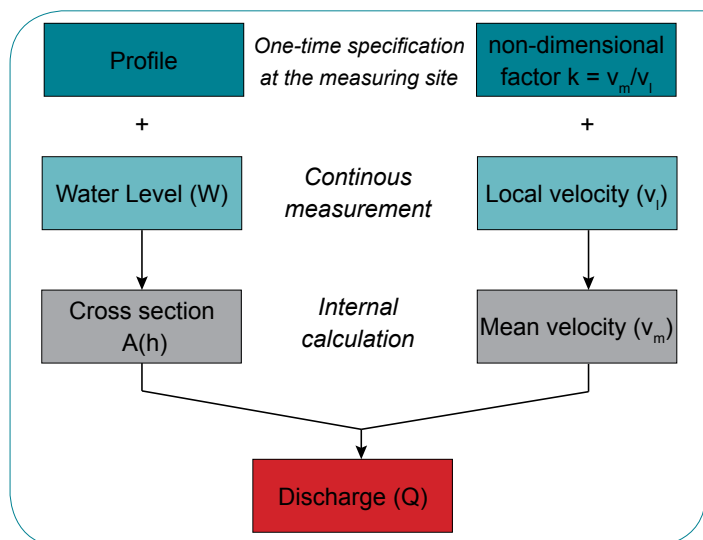

Pic: Chart discharge calculation

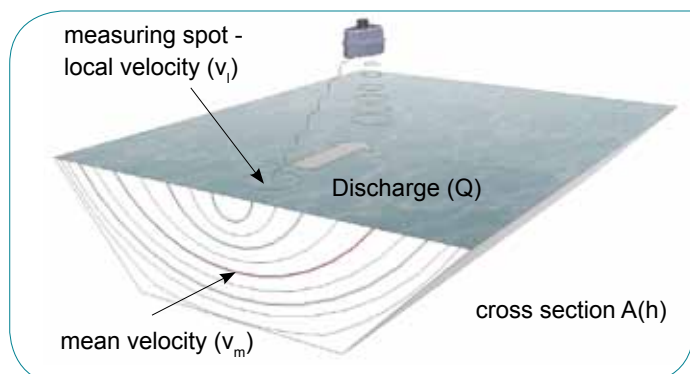

Pic: Illustration measuring principle



SQ in technical channels

Process water, shafts, semi-filled pipes etc.

Broad field of application

The SQ can be used for various different applications due to its compact design, its housing, which is water-proof and resistant against aggressive liquids, and its convenient and simple installation solutions. Open channels, semi-filled pipes, shafts, ducts and other technical bodies of water are possible applications for the measurement of process, waste and industrial water with the SQ.

Measuring range of the SQ

The mounting height above the lowest water level and hence the maximum measurement range for the level equals to 6 or 8 meters (depending on the sensor serial type). The measurement range for the flow velocity is between 0.08 and 15 m/s. An accurate discharge measurement is even possible despite high turbidity or solid contents in the water which commonly is the case in sewage.



Pic: Mounting cube: vertical / horizontal variable fixation

Advantages

- No construction in the water
- Simple installation and integration in existing monitoring and control systems
- Data output via multiple interfaces: SDI-12, RS-485, Modbus, analog (4 ... 20 mA), pulse signal
- Optional: non-contact measurement of water surface temperature





SQ in sewage treatment plants

In- and outlet monitoring, storm-water overflows

Modern facility management

The amount of water entering a sewage treatment plant is considered to be a key parameter. The continuous measurement of the flow rates is very important to guarantee smooth and effective operation. Regulation and control of the plant and its processes (as for example the proper functioning of the aeration basins) essentially depends on the current volume rates.

With its non-contact measurement technology the SQ flow meter is particularly advantageous for applications in wastewater with high turbidity and solid contents. Therefore the SQ ideally meets the needs and requirements of wastewater treatment plants.

Advantages

- Accurate flow measurement also with high turbidity or solid contents in the wastewater
- Discharge values as basis for cost accounting
- Dimensioning and control of plant and processes
- Discharge monitoring for (re)adjustment of calculation models





SQ in sewage systems

Discharge measurement and sewer monitoring

Monitoring flow rates

Accurate monitoring of their discharge rates is a major interest of municipalities, local authorities, sewage boards and operators of big sewer systems. Planning, allocation of costs and operation of the sewage network essentially depend on these data as well as the professional management of storm-water events. For this reason continuous and reliable measurements at key spots in the system or at storm-water overflow basins are a must.

The contact-free measuring flow meters of the SQ-series perfectly fulfil these requirements: Non-contact monitoring, therefore maintenance-free operation and uninterrupted, reliable measurement data through our innovative radar technology.

Increased safety during installation and maintenance

The mounting height above the lowest water level and hence the maximum measurement range for the level equals to 6 or 8 meters (depending on the sensor serial type). The measurement range for the flow velocity is between 0.08 and 15 m/s. An accurate discharge measurement is even possible despite high turbidity or solid contents in the water which commonly is the case in sewage.

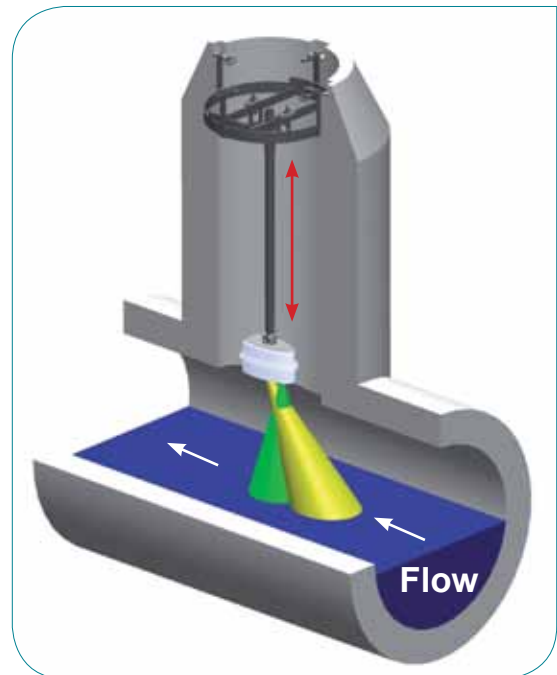

Pic: Illustration discharge measurement



Pic: Installation of SQ in the sewer

Advantages

- Application in aggressive environment possible
- Water-proof, tight housing
- Higher safety for staff and equipment
- Monitoring of very little discharge rates possible, since the sensor measures from above



Mobile, stand-alone station SQ Flow Meter, logger and data transmission

Self-supporting, independent and compact system

For remote measurement sites without permanent power supply and landline wire connection the SQ can be equipped for remote operation. Including a data logger and data transmission technology (2G/3G/4G modem) together with a strong battery pack the SQ becomes a strong self-supporting and independent system ideally suited for applications in the field or external measurement stations. Optionally the system can be upgraded with a camera for visualisation of the current situation.



Pic: Two emovable boxes (IP 68) for battery pack and data logger/modem housing - easy to access, easy to exchange, easy to store. All tight and water-proof.

Sommer Data Logger (MRL-7 or MRL-6)		
	Interface	COM interface (RS-232), USB and Bluetooth
	Memory	failure resistant flash memory 4 MB internal (equiv. to approx. 500.000 values)
	Functions	date/aggregate/mean values, intensity, maximum, etc.
	Battery	22 Ah, rechargeable accumulator - easy to exchange, lifetime of 10 weeks at a measuring interval of 5 minutes & 2 data transmissions per day
	Additions (optionally)	Solar panel camera for site visualisation
Integrated Modem for Data Transmission		
	Modem	remote data transmission with 2G / 3G (4G optionally) optionally: GPS for location detection
	Target server	up to three target servers (http / ftp) simultaneously
	Other characteristic	- independent transmission intervals possible - IP call activation for remote servicing - time synchronisation via NTP (Network Time Protocol)
Removeable Boxes	Material & characteristics	glass fibre reinforced plastic (GRP), IP 68, easy to exchange



System integration with PLC's

Flexible connections, wireless data transmission

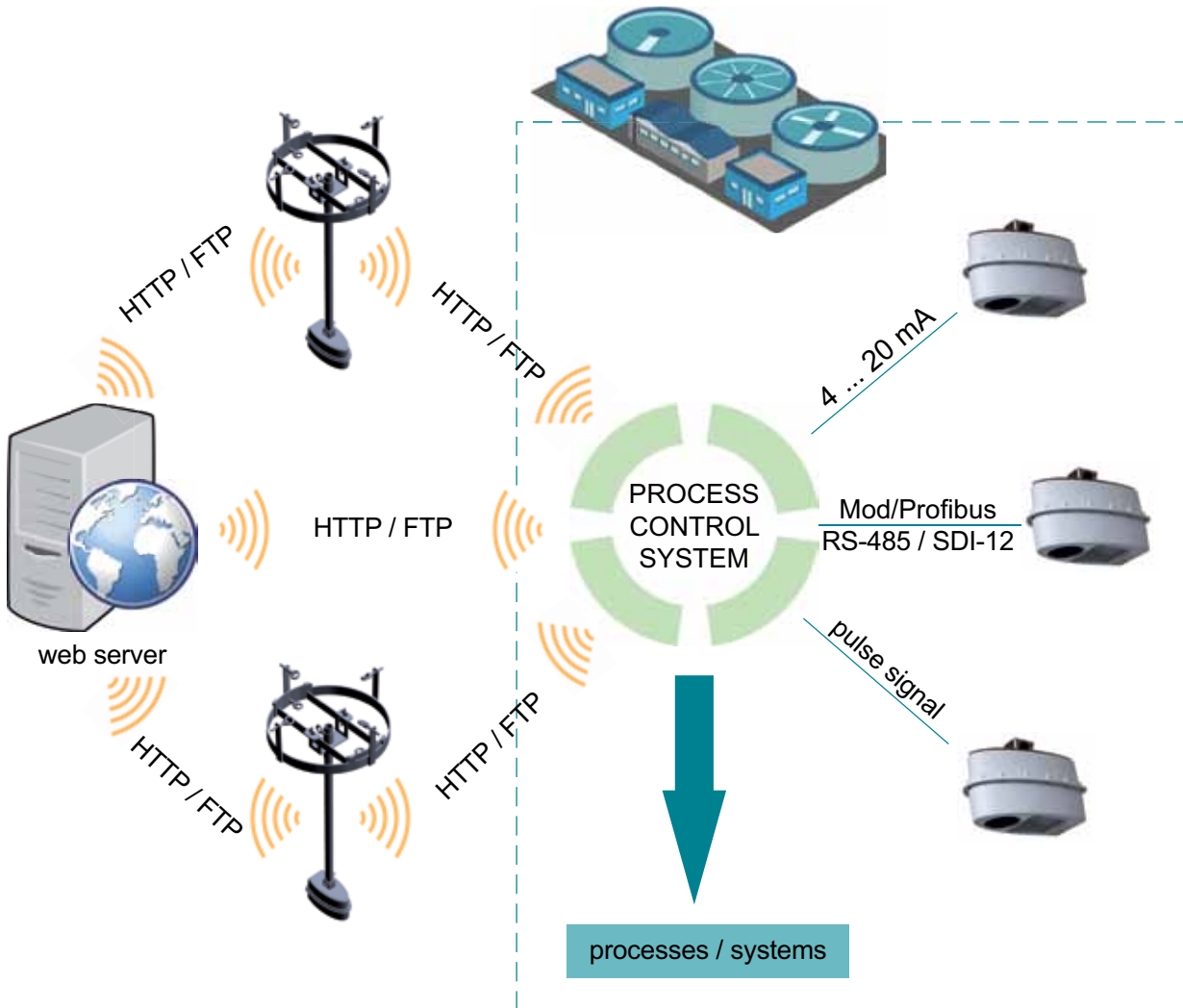

Pic: External monitoring sites (e.g. sewage system, waste, water channels, overflow basins)

Pic: Internal system (e.g. treatment plant, industrial process, facility)

Individual communication solutions

Inside the plant or process unit the SQ station can be integrated with the process control system (PLC) very easily, either via a digital interface (Modbus/Profibus, RS-485 or SDI-12) or an analog 4...20 mA connection (1x signal for water level, 1x selectable for flow rate or flow velocity). Moreover, a separate pulse signal can be provided. Outside or external stations communicate with the PLC remotely via a web server or directly, applying common HTTP or FTP protocols.



Q-Commander

The smart sensor software

Manage your measurement data

The Q-Commander is a very convenient tool to operate the SQ at the measurement site. The sensor can be accessed directly via its digital interface or remotely in case the site is also set up for data transmission.

Advantages

- Sensor software to conveniently manage your monitoring station and multiple devices
- Site calibration, up/download and editing of sensor parameters
- Post-processing of measurement data
- Advanced settings input for experts

Profile - create, amend, import or store profiles.

Communication assistant - connect the device(s) to the laptop and leading through the menu.

Parameter - modify parameters, adapt discharge table and upload parameters to the sensor.

Measurement - show, store measurement values.

Data - data files can be transferred, cleared, imported and are displayed in a diagram.

Terminal - shows the current activities of attached devices in terminal mode.

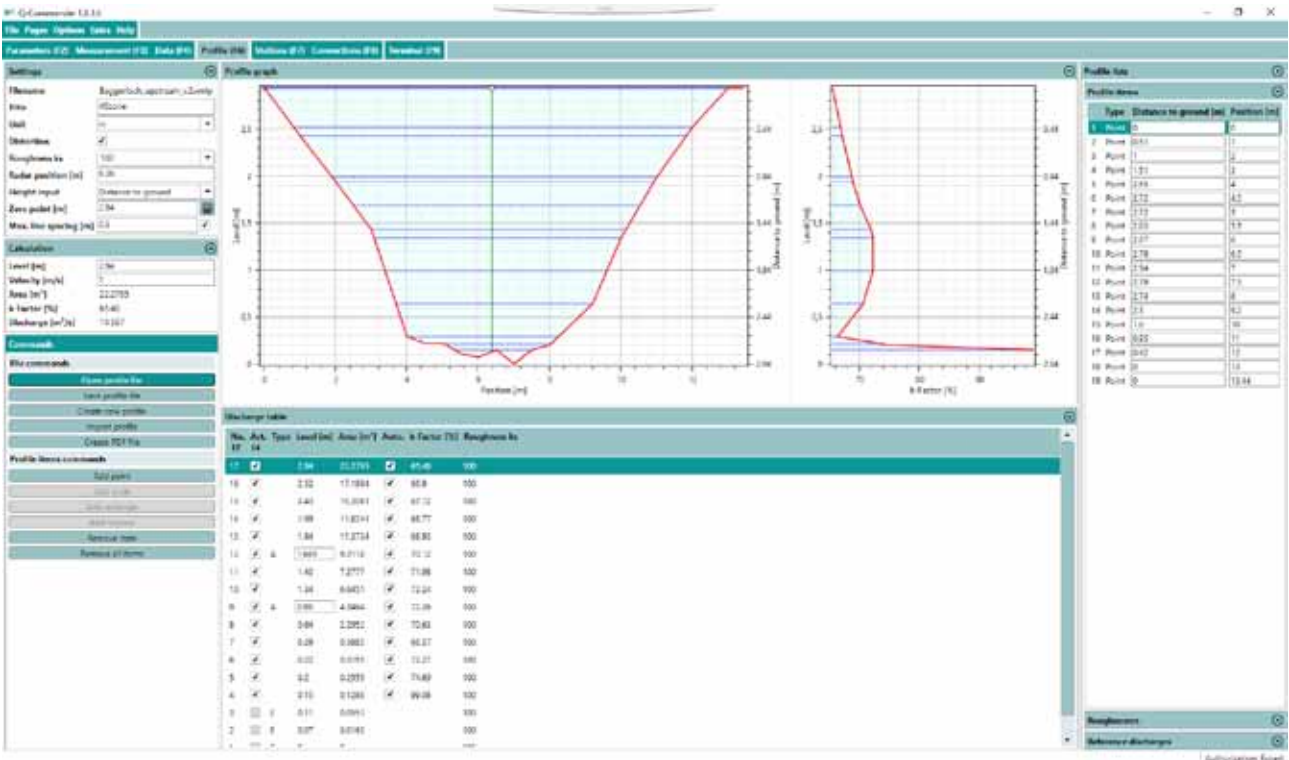



Cross section profiles

Preset, combinations or file imports

Choose your individual profile

profile has to be defined. The sensor software Q-Commander helps you to simplify this job offering a variety of pre-set geometries, combinations of the same or manual input.

Standard profiles and combinations

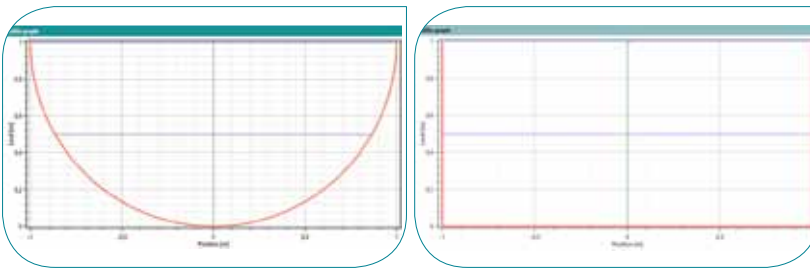

Standard profiles can be circular or rectangular and are created by simply entering its dimensions (e.g. height, width, diameter). The standard geometries can also be combined with each other.

Open / Closed and special profiles

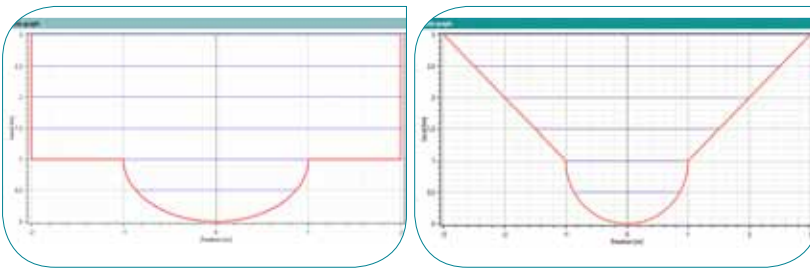

Open and closed cross sections can be entered just as simple. Moreover, it is possible to edit special and complex profiles entering multiple geometric points or by importing an existing profile, e.g. as CSV-file.

Online data on web server

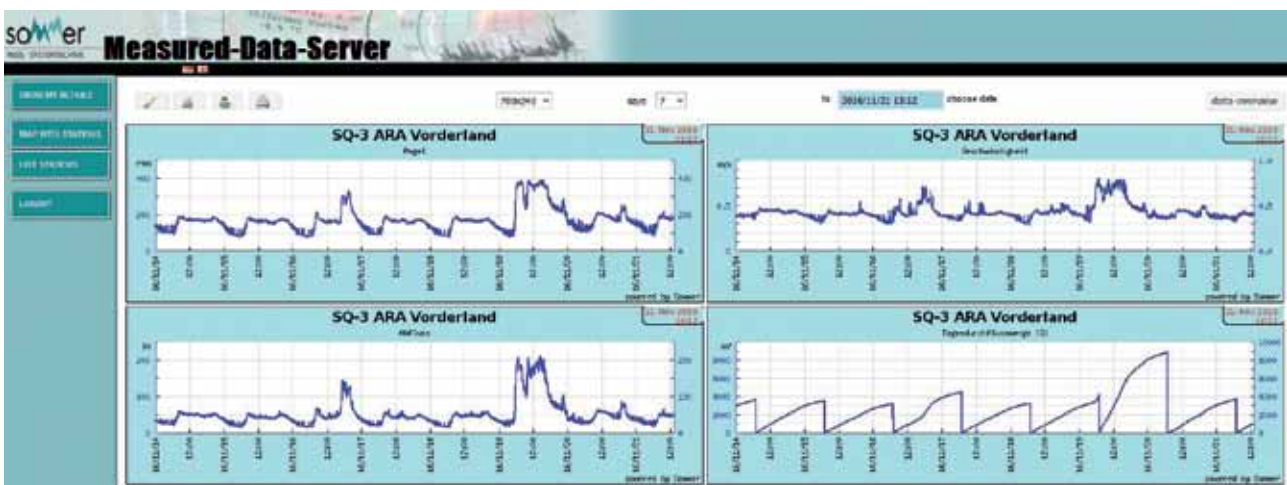



Technical details

Non-contact SQ flow meter

General			
Dimensions (mm)	272 x 153 x 186 (L x W x H) 1 bracket for pipe with Ø 30 mm		
Total weight	1.55 kg		
Protection class	IP 68		
Power supply	6 ... 30 V DC		
Consumption at 12 V	standby approx. 1 mA / active measurement approx. 140 mA		
Operation temperature	-35° ... 60° C		
Storage temperature	-40° ... 60° C		
Protection	over voltage protection, reverse power protection, lightning protection		
Level measurement			
Serial type	SQ-U	SQ-V	SQ-8R
Measuring technology	ultrasonic	-	radar
Level range	0 - 6 m / 0,82 - 19,67 ft	-	0 - 8 m / 0,16 - 26,25 ft
Resolution	2 mm	-	1 mm
Blanking distance	0.3 m	-	0.05 m
Accuracy	+/- 0.25 % FS	-	+/- 0.025 % FS
Frequency	•	-	26 GHz (k-Band)
Opening angle	12°	-	10°
Velocity measurement			
Detectable measurement range	0.08 ... 15 m/s (depending on flow conditions)		
Accuracy	+/- 0.01 m/s; +/- 1 % FS		
Resolution	1 mm/s		
Direction recognition	+/-		
Measurement duration	5 ... 240 sec.		
Measurement interval	8 sec. ... 5 hrs		
Measurement frequency	24 GHz (K-Band)		
Radar opening angle	12°		
Distance to water surface	0.10 ... 35.0 m		
Necessary minimum wave height	3 mm		
Automatical vertical angle compensation			
Accuracy	+/- 1°		
Resolution	+/- 0,1 °		
Interface			
Analog output (SQ)	2 x 4 ... 20 mA (1 x level; 1 x discharge or velocity - selectable)		
Analog output (SV)	1 x 4 ... 20 mA (1 x velocity)		
Pulse output	Pulse per volume (selectable units)		
Digital interface	1 x SDI-12 1 x RS 485 or Modbus Transfer rate: 1.2 to 115.2 kBd Protocol: various ASCII-protocols Output: discharge, flow velocity, level, quality parameters		



SV - surface velocity measurement

Technical water, shafts, semi-filled pipes etc.

Highly accurate surface velocity

The contact-free measuring flow and velocity meters of the SQ-series and SV-Series perfectly fulfil the future requirements:

- non-contact monitoring
- maintenance-free operation and uninterrupted
- reliable measurement data



Flow velocity

The measurement of the surface flow velocity is based on the Doppler frequency shift method: A radar signal is transmitted to the water surface at a constant frequency of 24 GHz. The sensor measures the partially reflected signal whose frequency is shifted due to the water movement. The surface velocity is determined through a spectral analysis. Finally, the mean velocity results by applying an integrated hydraulic model and is used for the calculation of the discharge (flow rate).

Advantages

- Highly accurate surface velocity measurement also with high turbidity or solid contents in the wastewater
- Maintenance free operation
- Valuable parameter of plant, system and processes
- Velocity monitoring for (re)adjustment of calculation models



Certificated accuracy

The accuracy of the flow velocity sensor has been certificated by METAS, the well-known Swiss Federal Institute of Metrology.



Non-contact SV velocity meter

General	
Dimensions (mm)	272 x 153 x 186 (L x W x H) 1 bracket for pipe with Ø 30 mm
Total weight	1.55 kg
Protection class	IP 68
Power supply	6 ... 30 V DC
Consumption at 12 V	standby approx. 1 mA / active measurement approx. 140 mA
Operation temperature	-35° ... 60° C
Storage temperature	-40° ... 60° C
Protection	over voltage protection, reverse power protection, lightning protection
Velocity measurement	
Detectable measurement range	0.08 ... 15 m/s (depending on flow conditions)
Accuracy	+/- 0.01 m/s; +/- 1 % FS
Resolution	1 mm/s
Direction recognition	+/-
Measurement duration	5 ... 240 sec.
Measurement interval	8 sec. ... 5 hrs
Measurement frequency	24 GHz (K-Band)
Radar opening angle	12°
Distance to water surface	0.10 ... 35.0 m
Necessary minimum wave height	3 mm
Automatical vertical angle compensation	
Accuracy	+/- 1°
Resolution	+/- 0,1 °
Interface	
Analog output (SV)	1 x 4 ... 20 mA (1 x velocity)
Pulse output	Pulse per volume (selectable units)
Digital interface	1 x SDI-12 1 x RS 485 or Modbus Transfer rate: 1.2 to 115.2 kBd Protocol: various ASCII-protocols Output: discharge, flow velocity, level, quality parameters

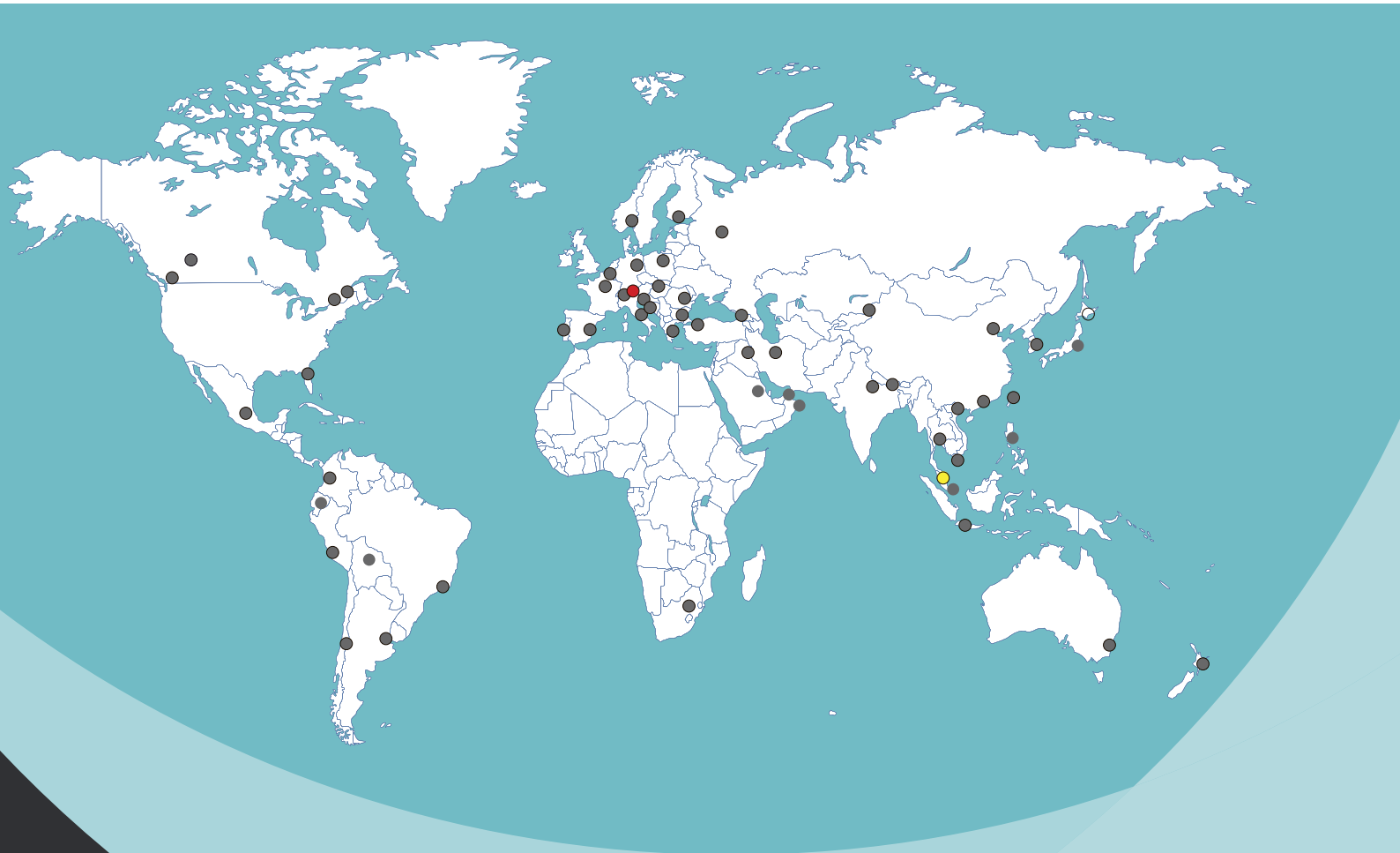

- SOMMER Head Office
- SOMMER S.E. Asia
- Sales Partners

Distributed by:

Lab Unlimited
CARL STUART GROUP

Tallaght Business Park
Whitestown, Dublin 24,
Ireland
D24 RFK3

Tel: (01) 4523432
Fax: (01) 4523967
E-mail: info@labunlimited.com
Web: www.labunlimited.com

Quatro House, Frimley Road,
Camberley,
United Kingdom
GU16 7ER

Tel: 08452 30 40 30
Fax: 08452 30 50 30
E-mail: info@labunlimited.co.uk
Web: www.labunlimited.co.uk

Sommer GmbH

Strassenhäuser 27, A-6842 Koblach
Tel.: +43 (0)5523 55989-0
Fax: +43 (0)5523 55989-19